

Understanding the Concept of Microcontroller Based Systems To Choose The Best Hardware For Applications

¹Yılmaz GÜVEN, ²Ercan COŞGUN, ³Sıtkı KOCAOĞLU
⁴Harun GEZİCİ, ⁵Eray YILMAZLAR

¹Kırklareli University, Technical Sciences Vocational School, Kırklareli, TURKEY)

²Kırklareli University, Technical Sciences Vocational School, Kırklareli, TURKEY)

³Kırklareli University, Technical Sciences Vocational School, Kırklareli, TURKEY)

⁴Kırklareli University, Technical Sciences Vocational School, Kırklareli, TURKEY)

⁵Kırklareli University, Technical Sciences Vocational School, Kırklareli, TURKEY)

Corresponding Author: Eray YILMAZLAR

Abstract: Today's technology has been evolved into stand-alone systems which can do all necessary process by itself without any additional hardware. Advance microcontrollers have become microcomputers that is also known as single board computers. These systems take their power from powerful microcontrollers. These microcontrollers have many integrated circuits onboard so they can achieve many different process by themselves. They are being used in many applications from powerful industrial device to simple home appliance. On today's market, there are many different microcontrollers with different structure and capabilities. Therefore, understanding the concepts related to the microcontrollers is really important for choosing the best hardware. This paper presents main concepts of microcontrollers and reveals basis of their structure. Their components and abilities have been discussed and comparison of well-known single board computers has been given.

Keywords: Integrated Circuits, Microcontrollers, Microcomputers, Hardware Optimization, Application Development

Date of Submission: 24-11-2017

Date of acceptance: 06-12-2017

I. Introduction

Microcontrollers and microcomputers from the beginning of the 1970s has developed rapidly since the beginning of the present day. Although they already have the functionality of only one calculator, they are now single-chip microcomputers (SOCs) that can perform all kinds of functions on all electronic systems. Microcontrollers with leading 8- and 16-bit processors are often preferred for low cost and ease of implementation. These systems, which can meet all kinds of needs for a long time, now have high processing capacity of 32 and 64 bits. The development process of the microcontrollers is shown in table 1.

Microcontroller	Processor	Bit Length	ClockFrequency	Year
TMS1802	Intel 4004	4 bit	740 KHz	1971
68HC05	Motorola 6800	8 bit	2 MHz	1974
MCS-48	Intel 8048	8 bit	11 MHz	1976
MSP430	Intel 8096	16 bit	12 MHz	1982
AT89C51	Intel 8051	8 bit	24 MHz	1986
Am29000	Intel 80186	32 bit	25 MHz	1995
AT91SAM3X8E	Cortex-M3	32 bit	84 MHz	2004
LPC3000	Cortex-M4	32bit	250 MHz	2010

Table1:The development process of the microcontrollers

Over time, many companies have moved to various microcontroller markets with different features. In recent years 64-bit microcontrollers have been introduced to the market and have been preferred for many applications in microcontrollers designed on a single card. The choice of integrated circuits, the provision of suitable environments for the operation of these circuits, and the complexity of programming stages have led users to microcomputers designed on this single card. These application development cards, which are provided

with the necessary conditions for the operation and programming of the microcontroller, can perform many functions on its own by means of internal hardware. Microcomputers, on the other hand, have more system resources and interfaces, so they can perform multiple functions more strongly.

In universities all courses with automation, robotics, communication and control contents are mentioned with these microcontroller based systems. Various microcontroller application development cards and microcomputers are used in the applications performed by the students. The purpose of this study is to give some background information about what kind of hardware infrastructure should be chosen during the application development phase. First of all, it will provide information about microprocessor architectures and microcontroller types. Then, some of the current microcomputer systems will be examined and suggestions will be made about what kind of hardware should be preferred in which applications with various application examples.

II. Microprocessors

Microcontroller and microcontroller concepts are often intermingled. While each microcontroller has a microcontroller in the center, not every microcontroller is a microcontroller. Microprocessors are programmable integrated circuits that can perform mathematical and logical operations on digital inputs. Basically it consists of a single chip which contains the register areas required for the operations as well as the input / output units and the data paths that provide the communication between them, as well as the transistor based structure (Osborne, 1980: 12).

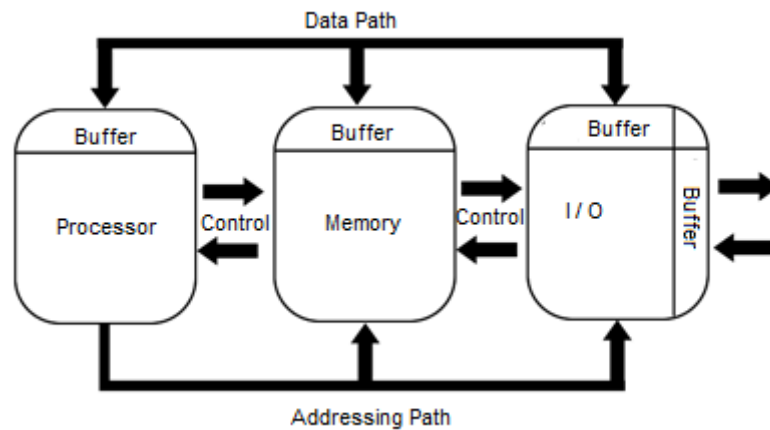

Figure 1: Block diagram of microcontrollers

The general structure of the microcontroller shown in Fig. 1 includes different units such as ALU (Arithmetic Logic Unit) where arithmetic and logic operations are performed, memory units (Accumulator) where the result of these operations are recorded, and recording units (Registers) where important information is recorded. Three different ways of communicating data, addressing information and control commands between these units are used (Hall, 1994: 15).

2.1 Microprocessor Architectures

Although the general structures are similar to each other, the microprocessors are manufactured in two different architectures Von Neumann and Harvard architectures. The most important difference between these two architectures is memory organization and instruction processing technique. In Von Neumann architecture, the data and program instructions are combined, but the data and program instructions are separated in Harvard architecture. Although Von Neumann architecture has been used for many years, today almost all microprocessors are produced with Harvard architecture (Godfrey and Hendry, 1993: 11-12).

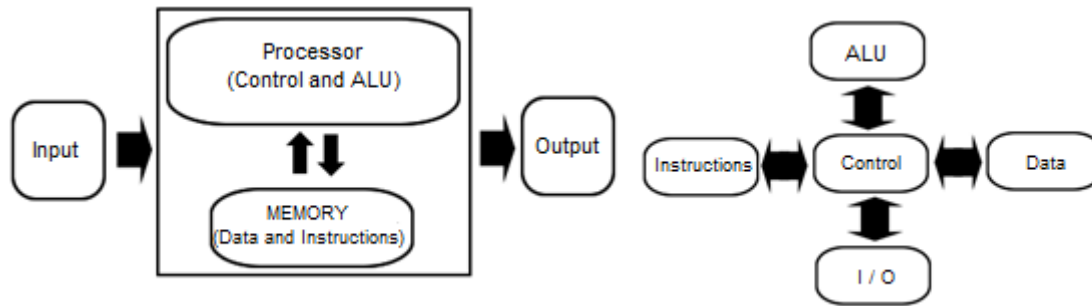

Figure 2: a)Neumann Architecture

b)Harvard Architecture

2.2 Instruction Set Structure

According to the instruction sets, it is correct to separate the two classes of microprocessors. Although complex instruction set (CISC) processors have been around for a long time, reduced instruction set (RISC) processors have been developed to simplify the complex architecture and provide more efficient use. In contrast to what is suggested by the name, the reduced instruction set contains fewer commands. Only commands are abbreviated to speed up the operation (Jones).

RISC	CISC
Fast	Slow
Basic Hardware Requirements	High Hardware Requirements
Basic Hardware Design	High Hardware Design
Single Cycle	Multiple Cycle

Table 2: Comparison of complex and reduced instruction sets

Today, processors used in computer technology have CISC architecture. RISC architecture is preferred in simple systems with fewer hardware resources, as seen in Table 2. Frequently preferred microcontrollers in electronic applications use processors with RISC architecture.

2.3 Additional Hardware

Microprocessors are manufactured with equipment designed for special purposes. It is important that these equipment, which are needed according to the application diversity, directly affect the performance. Units such as digital signal processing (DSP), graphics processing unit (GPU) or decimal-point unit (FPU) must be used if required in the intended application.

Hardware	Function
DSP (Digital Signal Processor)	Digital signal operations
GPU (Graphic Processing Unit)	Visual creation and processing
FPU (Floating Point Unit)	Handling very large and small numbers
ALU (Arithmetic-Logic Unit)	Mathematical and logical operations
APU (Acceleration Processing Unit)	Hardware acceleration

Table 3: The functions of additional hardware

Microcontrollers can handle hundreds of thousands of integrated circuits and can perform routine and long operations quickly; all of which are integrated electronic circuits that provide the least space and provide the lowest energy consumption. Basically a central processing unit consists of register fields and input / output units, but may also contain additional integrated circuits that can perform special functions. When choosing a processor, attention should be paid to technical features such as word processing length, working clock frequency, memory amount, bus width and internal additional hardware as well as the compatibility of the codes to be operated with the instruction set and processor architecture. In short, since the microprocessor is the heart of the microcontroller, a microcontroller can be as powerful as a microcontroller. This means that hardware optimization begins with choosing the right processor for application development.

III. Microcontrollers

A microcontroller is an integrated circuit that is housed within each component that it needs to perform the necessary operations and that can perform a particular task routinely without requiring another boom. It contains a microprocessor, memory units and input-output interfaces, analog-to-digital conversion (ADC), pulse width modulation (PWM) and various control and communication modules.

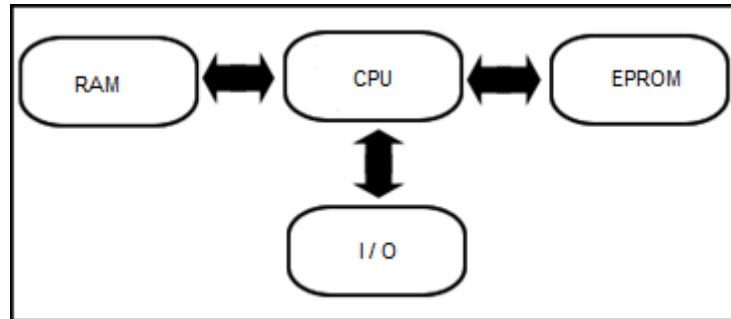

Figure 3:General block diagram of the microcontrollers

Besides the arithmetic-logical unit (ALU), special registers, processor control unit and processor core in the processor, the microcontroller has memory units with special functions. They can be divided into fixed and temporary memories. Random access memory (RAM) stores the information that the processor needs during its operation, while ROM, PROM, EPROM, and EEPROM memories, which do not change the contents, store information such as command set, program and program data as long as they are not reprogrammed. Input and output are special recording areas that allow the microcontroller to receive data from external units and send data (Gridling and Weiss, 2007: 11-35).

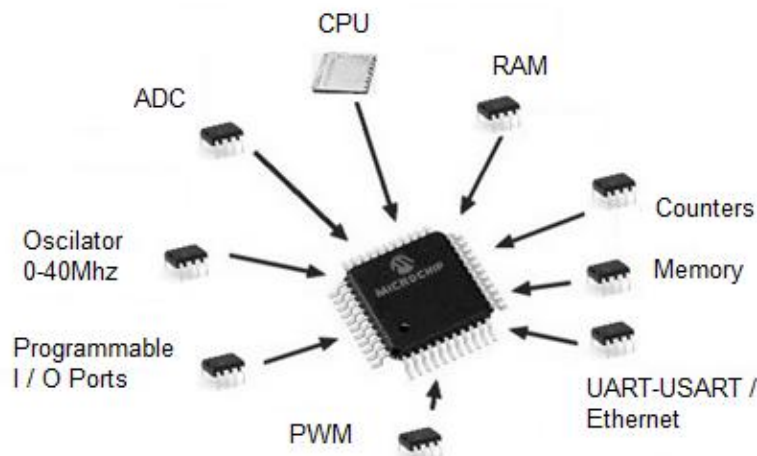

Figure 4: Internal components of the microcontrollers

3.1 Microcontroller Types

Microcontrollers are generally classified according to processor characteristics such as processor architecture, processor word processing length, processor clock operating frequency, and so on. While RISC architectural microprocessors are generally preferred in electronic applications such as control and automation, CISC architectures are used in microcomputer applications such as signal processing and embedded systems. Some important features that distinguish microcontrollers from each other are listed below.

- Processor Architecture: type of application and command set used
- Processor word length: length and type of data to be processed
- Processor clock frequency: The processing speed of the codes to be executed
- RAM and ROM capacities: The area covered by the program and program data
- Input / Output units: Data exchange and communication with external media
- Built-in enhancements: Special enhancements required
- Form factor: Physical structure and working environment
- Operating conditions: Supply voltage, electromagnetic compatibility, compatibility with other circuits

3.2 Microcontroller Selection

It may be confusing for beginners to decide which microcontroller to use when developing an application. While choosing the right microcontroller helps the user in the later stages of implementation, it can cause the application to be blocked at some point and returned to the planning stage with the wrong microcontroller. The following steps can be followed to select the microcontroller.

- List the equipment required for the application:

Specify the hardware needed for communication interfaces (USB, SPI, UART etc.) and special processes (ADC, PWM, DSP, FPU). Also list the port connections you will use for the input / output elements such as sensor, LCD display, driver and relay.

- Observe your software architecture:

Specify the length of the program to be operated and the operating speed. The content of the codes to be operated and the frequency of operation will determine your hardware requirements.

- Specify the hardware architecture:

Determine your hardware architecture based on the length of the data to be operated and the variety of instructions.

- Specify the memory requirement:

Specify the area of the program and program data that is required for the application. Calculate the RAM memory required to operate this program.

- Cost and energy consumption analysis:

Check the cost and availability of the equipment to be used. Check your application's energy consumption, operating frequency and other variables.

- Examination of software development environment:

Check the development environment and programming languages provided for the hardware you have selected.

- Exploring the compiler and other development tools:

Search the programming interfaces and tools to be used.

- System testing and application experiments:

If possible, conduct small practice tests to check that each system you use will be compatible with your system and working (Beningo, 2014).

3.3 Application Development Cards

The most used microcontroller and application development cards will be examined in this section. 8 and 16 bit microcontrollers with RISC architecture and some application development boards with 32 bit CISC architecture will be examined and compared according to their characteristics. Anyone who starts dealing with microcontrollers will definitely start using PIC or ATMEL microcontrollers. In addition to their simplicity and low cost, they are also contributed by many compilers and programming languages.

These firms, which produce many microcontrollers of 8 and 16 bits for many years, also produce much more powerful 32-bit microcontrollers today. Over time, many companies have provided different software development environments with program development cards for these microcontrollers. Many commercial companies and non-profit organizations have set up their own development environments and introduced them to users at low cost, ready to develop 32 bit microcontrollers for companies such as Intel and ARM. Although the 64-bit microcontrollers do not seem to be available to end users yet, each 64-bit microcontroller manufactured today can be thought of as a microcontroller built into a microcontroller or a single chip because it contains various hardware.

	PIC	AVR	ARM	Intel	MSP
EasyPIC	8, 16 bit	8 bit	32 bit	8 bit	-
Expkits	8, 16 bit	-	32 bit	-	-
Tinylab	-	8 bit	-	-	-
SparkFun	8, 16, 32 bit	8, 16 bit	32 bit	32 bit	-
Arduino	-	8, 16 bit	32 bit	32 bit	-
Teensy	-	8 bit	32 bit	8 bit	-
Intel	-	-	-	8,16,32 bit	-
mbed	-	-	32 bit	-	-
TI	-	-	32 bit	-	16 bit
Beaglebone	-	-	32 bit	-	-
Nxp	-	-	32 bit	-	-

Table 4: Popular microcontroller development cards and supported processors

When choosing a microcontroller development card, it is necessary to consider a number of features such as card interface, intrinsic hardware, program development interface, operating voltage, input / output numbers as well as processor power and capacity. In addition, care must be taken to ensure both hardware and software compatibility of the extra equipment supporting the development board. When choosing a development card, the following must be observed:

- Supported processor types (PIC, AVR, AMR etc.)
- Communication interfaces (RS232, USB, UART, SPI, WiFi, Bluetooth etc.)
- Additional equipment on the card (LCD, Keypad, Button, Motor driver etc.)
- Electrical properties of the card (such as supply voltage, maximum current and electromagnetic compatibility)
- Software flexibility and supported compilers (programming languages and compiler variants)
- Expandable properties of the card according to the application (additional module and connection interfaces)
- Physical properties of the card (size, weight, working temperature etc.)
- Attention should be paid to features such as price, availability and after-sales software support of the card.

IV. Microcomputers

This section will review several current microcomputer systems. Single card computer systems (SBC) are used in many applications such as control, automation, signal processing. These systems, which can run multiple systems at the same time with powerful processor and high memory capacity, can be programmed through different platforms and can even run the operating system, is actually a long time in our lives. We have been using it for a long time, from the first calculators to mini-computers connected to television and even game consoles. The single-card computers that emerge from the development process of computer systems that everyone can access in the last few years are now preferred for many applications.

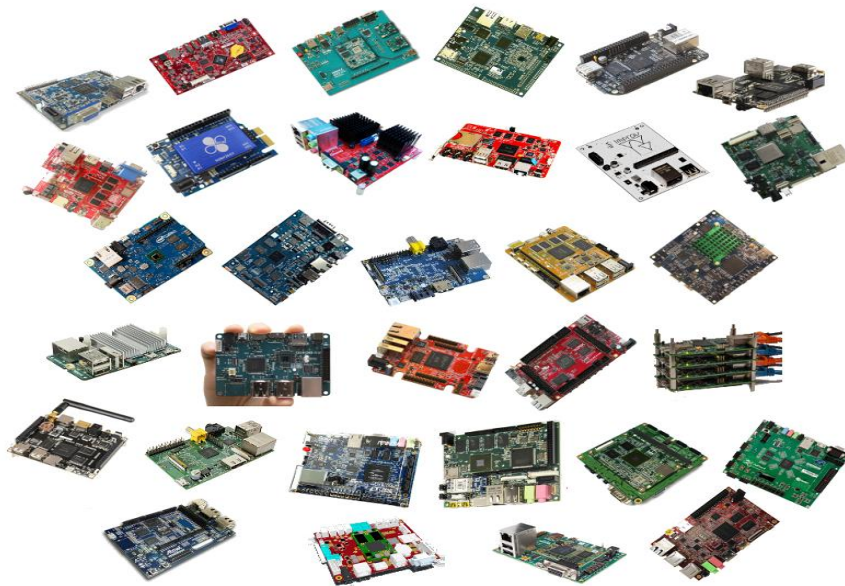

Figure 5: Single card computers

	CPU	GHz	RAM	ROM	USB	GPIO	Internet	Görüntü
Raspberry Pi 3	ARMv8	1.2	1GB	SD	4	40	Wifi+Eth	Hdmi+DSI
Raspberry Pi 2	Cortex-A7	0,9	1GB	SD	4	40	Ethernet	Hdmi+DSI
Raspberry Pi 1	ARM1176	0,75	512MB	SD	2	26	Ethernet	Hdmi+DSI
Raspberry Pi 0	ARM1176	1	512MB	SD	2	40	-	Hdmi
CHIP	ARMv7	1	512MB	4GB+SD	2	80	Wifi	-
Orange Pi 0	ARM	1.2	256MB	SD	2	13	Wifi+Eth	-
Orange Pi 1	Cortex-A7	1.2	512MB	SD	2	40	Ethernet	Hdmi
Orange Pi PC		1.6	1GB	SD	2	40	Ethernet	Hdmi+cvbs
Orange Pi +		1.6	1GB	8GB+SD	4	40	Wifi+Eth	Hdmi+cvbs
HummingBoard	Cortex-A9	1.2	2GB	SD	4	30	Ethernet	Hdmi
BeagleBone	ARM	0.7	256MB	SD	2	80	Ethernet	Hdmi
Black	Cortex-A8	1	512MB	4GB+SD	2	80	Ethernet	-
Green		1	512MB	4GB+SD	2	80	Ethernet	-

Enhanced		1	1GB	4GB+SD	4	80	Ethernet	Hdmi
Gelileo	İntel Quark	0,4	256MB	8MB+SD	2	40	Ethernet	PCI-ex
Edison	İntel Atom	0,5	1GB	4GB+SD	1	40	Wifi+Eth	-
Joule	İntel Atom	1,7	3GB	8GB+SD	4	48	Wifi	Hdmi
Banana Pi M1	ARM	1	1GB	SD	2	40	Ethernet	Hdmi+cvbs
Banana Pi M2	Cortex-A7	1,2	1GB	SD	4	40	Wifi+Eth	Hdmi+rgb
Banana Pi M3		1,8	2GB	8GB+SD	2	40	Wifi+Eth	Hdmi+DSI

Table 5: Popular single card computers and general features

Single-chip microcomputers with a wide range of applications thanks to their different processor and memory capacities as well as the different interfaces they have (Ethernet, Hdmi, DSI, CVBS, PCI-ex etc.) are also used in electronic applications with general purpose inputs and outputs (GPIOs). These cards, which can be wired or wirelessly connected internally, have wireless communication options such as Bluetooth, and support industrial communication standards, are embedded systems that house both the control system and the control system. It is very easy to use for educational purposes due to low costs and widespread software support. Even in the future, taking up the space of bulky desktop computers that occupy a lot of space, will be programmed for special purposes to provide more efficient use.

V. Conclusion

In recent years, the number of applications developed using microcontrollers has increased rapidly. A variety of microcontroller development cards are used in most of the courses in the universities. These systems, which are also preferred in student projects, are increasing in importance due to the large number of hardware and the large software support. However, when there are many different types of microcontroller and application development cards on the market, it is observed that students have difficulty in where to start. In addition, they are unfamiliar with the basic concepts of microprocessors and microcontrollers, so they are inadequate in selecting the necessary hardware for reading and implementing technical documents.

Rapidly evolving microcontroller technologies now become embedded systems that can do all the work at the same time with single card computer systems. Many of these systems, which are open source, are becoming more and more popular. Linux, Android and Windows, as well as its own operating systems, automation and control systems, as well as image and signal processing can perform many functions. It is aimed that this work will be a guide for newcomers to microcontrollers and embedded systems.

References

Journal Papers:

- [1]. M.D. Godfrey and D.F. Hendry, "The Computer as von Neumann Planned It," IEEE Annals of the History of Computing, Vol. 15, No. 1, 1993, pp. 11-21.
- [2]. Osborne, Adam (1980). An Introduction to Microcomputers. Volume 1: Basic Concepts (2nd ed.). Berkeley, California: Osborne-McGraw Hill. ISBN 0-931988-34-9.
- [3]. Douglas W. Jones, A Minimal CISC; Part of the Computer Architecture on-line Collection. University of Iowa Department of Computer Science. <http://homepage.divms.uiowa.edu/~jones/arch/cisc/>, 02 January 2017.
- [4]. Gridling, G. ve Weiss B. Introduction to Microcontrollers. Course 182.64-74.Vienna University of Technology.Institute of Computer Engineering. 26 February 2007.
- [5]. Beningo, J. 10 Step to Selecting a Microcontroller. ARM Embedded Communities. 12 Jan 2014. <https://community.arm.com/iot/embedded/b/embedded-blog/posts/10-steps-to-selecting-a-microcontroller>, 11 February 2017.

Books:

- [6]. Hall, V. D. (1994). MikroişlemcilerveSayısalSistemler.MEB Publications, Eskişehir, Turkey.